

## Descrição / Características

Estrutura tubular desenvolvida com maior número de parafusos, proporcionando maior segurança a vazamentos externos aumentando a robustez da válvula.

Dotada de guias de apoio para alojamento dos parafusos, o que proporciona maior resistência, eliminando empenamento das tampas.

Válvula tripartida com exclusivo sistema de vedações enclausuradas que aumenta a resistência das sedes de vedação, melhorando o desempenho da válvula.

Acionamento manual por alavanca com ou sem trava para cadeado ou lacre, disponível também com acionamento por atuador pneumático, elétrico ou caixa de redução.

## Dados Técnicos

EDIÇÃO 02 - 07 / 2020

### Normas de Referência

Construção: **ASME B 16.34 | ISO 17292  
API 608**

Testes: **API 598 | ISO 5208**

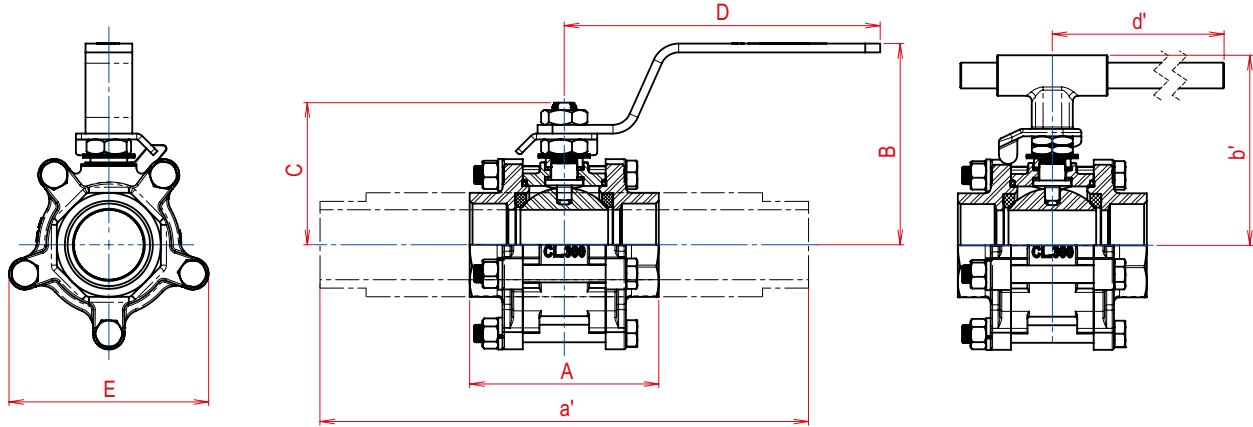

Para válvulas com conexão soldada, exceto niple 100mm, recomenda-se a instalação de um novo conjunto de vedação após a soldagem da válvula na rede.

### TIPOS DE CONEXÕES

ENCAIXE DE SOLDA SW

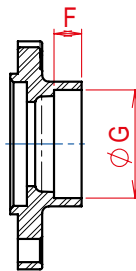

PONTA P/ SOLDA DE TOPO

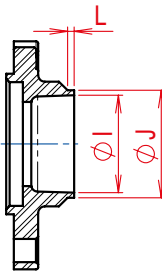

ROSCA BSP OU NPT

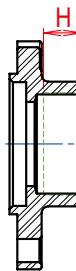

NIPLE ESTENDIDO (Face Plana)

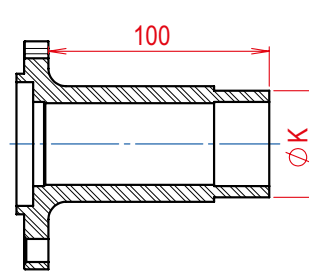

VÁLVULA DE ESFERA TRIPARTIDA PASSAGEM REDUZIDA (PR)																					
BITOLA	POL.	DN	PASS.	A*	a'	B	b'	C	D	d'	E	F	G	H	I	J	K	L	N.º DE PARAF.	PESO kg	Coefficiente de Fluxo Kv (m³/h)
1/2"	15	11,1	55,0	-	44,0	-	39,5	125,0	-	44,5	9,5	22,0	12,0	15,8	21,8	-	2,0	4	0,433	5,0	
3/4"	20	14,0	64,0	-	46,5	76,0	41,5	125,0	225,0	48,5	12,5	27,4	14,0	20,9	27,1	-	2,0	4	0,546	9,8	
1"	25	20,4	73,0	-	78,2	87,0	55,4	165,0	225,0	57,0	12,5	34,1	15,0	26,4	33,8	-	2,0	4	0,920	18,7	
1.1/4"	32	25,4	84,0	-	82,0	90,5	59,0	165,0	225,0	83,0	12,5	42,9	16,0	35,0	42,6	-	2,0	5	1,360	42,0	
1.1/2"	40	31,7	93,7	-	102,0	98,5	72,5	182,0	225,0	93,0	12,5	49,0	18,0	41,0	48,7	-	2,0	5	2,155	72,0	
2"	50	38,0	108,7	-	109,0	103,0	77,0	182,0	225,0	108,2	16,0	61,4	20,0	52,5	61,4	-	3,0	5	2,855	107,0	
• 2.1/2"	65	50,8	130,4	-	126,0	112,5	86,0	255,0	225,0	130,5	16,0	74,1	25,0	62,7	73,8	-	3,0	6	4,710	185,0	
• 3"	80	63,0	160,2	-	146,0	147,5	114,0	267,0	415,0	153,0	16,0	90,1	26,0	78,0	90,1	-	3,0	6	8,015	305,0	
• 4"	100	76,0	178,0	-	154,4	163,0	126,7	335,0	490,0	177,0	19,0	115,4	34,0	106,5	115,5	-	3,0	6	11,450	1050,0	
• 5"	127	101,6	243,0	-	-	185,0	-	-	490,0	222,0	25,0	142,0	46,0	133,0	141,5	-	3,0	8	25,600	1980,0	

VÁLVULA DE ESFERA TRIPARTIDA PASSAGEM PLENA (PP)																					
BITOLA	POL.	DN	PASS.	A*	a'	B	b'	C	D	d'	E	F	G	H	I	J	K	L	N.º DE PARAF.	PESO kg	Coefficiente de Fluxo Kv (m³/h)
1/4"	8	11,1	51,0	-	44,0	-	39,5	125,0	-	44,5	9,5	14,4	11,0	11,1	14,0	-	2,0	4	0,425	5,0	
3/8"	10	11,1	51,0	-	44,0	-	39,5	125,0	-	44,5	9,5	17,8	11,0	14,5	17,6	-	2,0	4	0,421	5,0	
1/2"	15	14,0	60,0	239,0	46,5	76,0	41,5	125,0	225,0	48,5	9,5	22,0	12,0	18,0	21,8	21,3	2,0	4	0,508	9,8	
3/4"	20	20,4	70,0	247,0	78,2	87,0	55,4	165,0	225,0	57,0	12,5	27,4	15,0	23,0	27,1	26,7	2,0	4	0,866	18,7	
1"	25	25,4	82,0	252,5	82,0	90,5	59,0	165,0	225,0	83,0	12,5	34,1	16,0	29,6	33,8	33,4	2,0	5	1,310	42,0	
1.1/4"	32	31,7	90,7	262,7	102,0	98,5	72,5	182,0	225,0	93,0	12,5	42,9	18,0	38,0	42,6	42,2	2,0	5	2,079	72,0	
1.1/2"	40	38,0	102,7	267,0	109,0	103,0	77,0	182,0	225,0	108,2	12,5	49,0	19,0	44,1	48,7	48,3	3,0	5	2,717	107,0	
• 2"	50	50,8	120,1	279,0	126,0	112,5	86,0	255,0	225,0	130,5	16,0	61,4	22,0	56,2	61,4	60,3	3,0	6	4,258	185,0	
• 2.1/2"	65	63,0	152,4	-	146,0	147,5	114,0	267,0	415,0	153,0	16,0	74,1	27,5	70,0	73,8	-	3,0	6	7,593	305,0	
• 3"	80	76,0	169,4	-	154,4	163,0	126,7	335,0	490,0	177,0	16,0	90,1	29,0	84,0	90,1	-	3,0	6	10,110	1050,0	
• 4"	100	101,6	209,0	-	182,0	185,0	-	-	490,0	210,0	19,0	115,4	35,0	112,5	115,5	-	3,0	8	21,900	1980,0	

A vazão apresentada em Kv (m³/h) corresponde a um diferencial de pressão (Δp) de 1 bar utilizando água como fluido de teste.

• Sob consulta, disponível com esfera oca.

\* As válvulas de 4" PP nas configurações "AC" e "TI" e, a válvula de 3" PP na configuração "TI", com acionamento manual estão disponíveis somente por tubo.

\* Para conexão BW, medidas sob consulta.